

SAKOP 2/3 TERMINAL CABINET OF NORMAL DESIGN

APPLICATION AREA

SAKOP-2/3 terminal cabinet of normal design is suitable for the following purposes:

- Making straight through connections between two sections of telecom cables
- Making straight through connections and branching of lines

APPLICATION CONDITIONS

The device is suitable for working areas of underground operations without the hazard of methane explosion and the ones with the 'a' degree of methane explosion hazard as well as with the 'A' class of coal dust explosion hazard.

CONFORMITY WITH STANDARDS

SAKOP 2/3 branching terminal cabinet of normal design are manufactured in line with rules of good engineering practice in the field of occupational safety as well as current state-of-art in technical expertise with consideration to applicable technical standards and the 2014/35/UE Low-Voltage Directive.

DESIGN

Standard terminal cabinet are made of carbon steel sheets protected against corrosion by coating with paint of the RAL 7032 colour. Terminal cabinets made of stainless steel are also available upon request (designated with the 'N' letter in their product code).

TECHNICAL PARAMETERS

Cabinet type		SAKOP 2/3
Rated voltage		250 V
Number of terminals		(2 x 100)
Maximum cross-section of cores		0.8 mm ²
Number of earthing terminals	inside	6+2
	outside	1
Cable inlet bushings of WK type for cables with the following diameters:		max. 8 items
- WK1 – 21 mm		
- WK2 – 32 mm		
- WK3 – 38 mm		
- WK4 – 50 mm		
Enclosure index of protection		IP 54
Overall dimensions (W x H x D)		300 x 400 x 150 mm

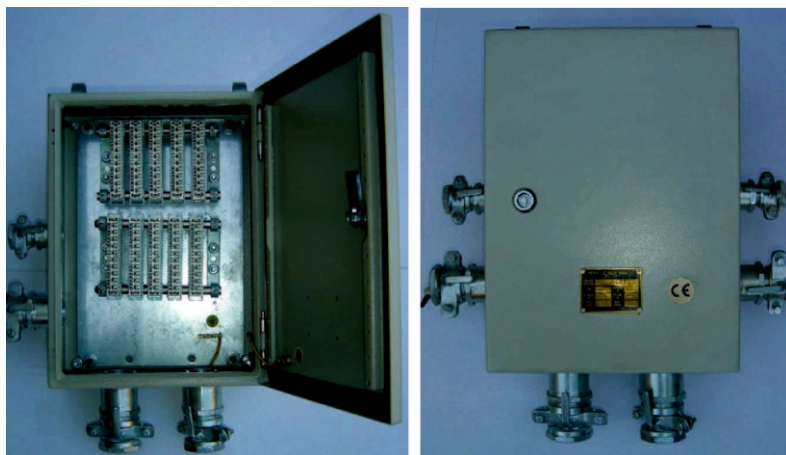
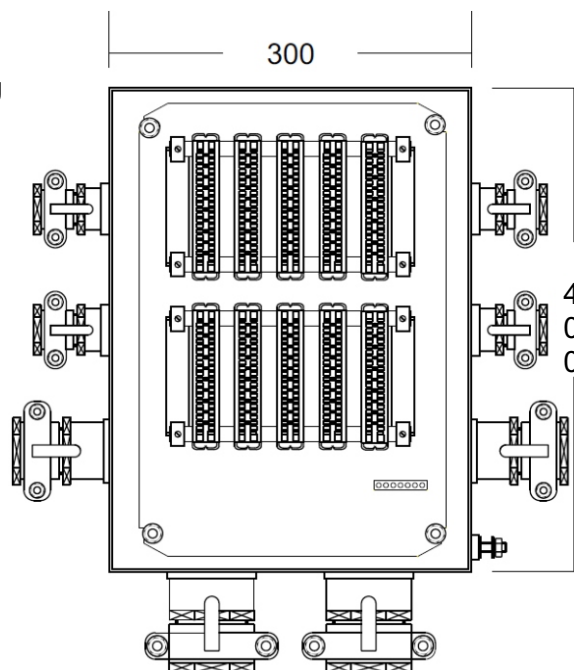

PLACING OF ORDERS

SAKOP 2/3 terminal cabinet – the cabinet made of carbon steel sheets and coated with RAL 7032 paint

SAKOP 2/3N terminal cabinet – the cabinet made of stainless steel.